

SPECIFICATIONS – ACCESSORIES: PRIMING SYSTEMS

PRIMING PUMP AND PRIMING VALVE



A Waterous priming system consists of a priming pump and a priming valve. The priming pump draws air out of the centrifugal pump through the priming valve. The priming valve must be open when priming the pump and then closed when the pump is fully primed (pumping water with all air removed).

What is Priming?

Priming is the process of replacing air in the intake lines and portions of the pump with water. If the pump is to be operated from draft, priming must be done by means of a positive displacement pump, or some other device for creating a partial vacuum. Also, when pumping from a water tank, priming will be accomplished more quickly and positively if a priming device is used. Priming will occur naturally when pumping from hydrants or in relay because inlet water pressure is high enough to force air out of the pump and intake lines, providing a discharge line is opened to permit the air to escape.

Description

Time is vital when priming a pump. The Waterous oil-free rotary vane primer is a reliable performer that gives a fast, positive prime. A combination of high capacity and high vacuum producing ability assures rapid priming. This electric motor primer allows you to reprime while pumping without reducing engine RPM because it does not rely on engine vacuum or exhaust. Electric motor driven primers also may operate with the engine stopped.

Engineered to provide a long operating life, the simple design of the Waterous priming system means fewer moving parts and easy maintenance. Rotating parts in the VPO and VPOS are made of corrosion-resistant, anodized aluminum, stainless steel and composite materials.

The VPO and VPOS can be mounted directly on a Waterous split-shaft pump transmission or separately mounted in any convenient location.

A Waterous rotary vane primer, when combined with a Waterous priming valve forms a priming system that will give you years of reliable performance.

To compliment your rotary vane primer, the Waterous vacuum activated priming (VAP) valve opens automatically during pump priming. When the valve is open, it allows air to flow from the various pump passages to the priming pump. Once the pump is primed, the priming valve closes automatically when the primer is deactivated.

Also available are the manual electric and fully automatic priming valves. Both are made of stainless steel, bronze and other corrosion-resistant materials.

These systems permit a primer to evacuate several regions of the main pump and auxiliary piping simultaneously.

A lubrication option allows the use of Prime-Safe™ lubricant. A priming tank is required when the lubrication option is selected.

Industry Leading Sales and Support

When you purchase equipment, not only do you get quality products, you get quality service. Our expert service technicians are the best in the business and they are always happy to answer any service questions you might have.

Sales/Applications Assistance
Phone: 651-450-5234 (Press 3)
pumpsales@waterousco.com

Service Assistance
Phone: 651-450-5200
Fax: 800-488-1228
service@waterousco.com

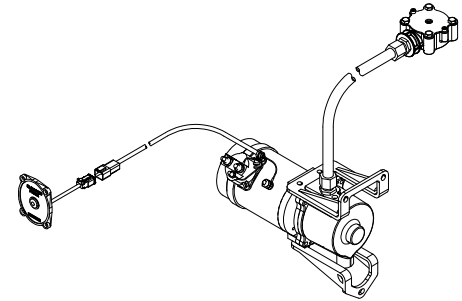

Priming Pump

The VPO electric motor driven rotary vane primer is mounted directly on a Waterous midship pump transmission. A separately mounted model VPOS is also available. With the priming valve, it forms a complete, dependable, factory installed priming system.

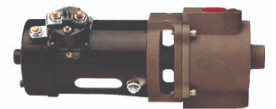

Vacuum Activated Priming Valve (VAP)

This valve consists of a stainless steel valve stem, spring and pressure disk in a plastic valve body. A rubber disk forms the seat for the valve stem and also forms a seal between the priming valve inlet and the pump body. A rubber diaphragm forms a seal which allows the valve to open and close while isolating the interior of the priming valve from atmospheric pressure.

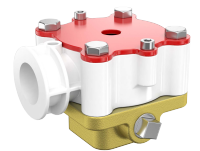

Optional AUTO-PRIME FEATURE:

Consists of a Pressure Switch which is installed in the pump and connected to the priming pump motor.



When the switch detects a drop of 10 psi in pressure, the priming pump is activated.

Optional Priming Lubricant

Lubricant may be used to help seal and lubricate the priming pump.

THEN, NOW, ALWAYS. MOVING FORWARD.